

IN-Series

Trim Removal Inducers



The IN Series: trim removal component for use with asr® systems to recycle edge trim, roll scrap and loose scrap individually or simultaneously (pictured above is an IN 415)

PROCESS CONTROL's IN Series Inducers are designed to pick up and convey edge and / or bleed trims generated in the production of plastic film or other thin-gauge products such as foam, tape, paper or foil. These continuous trims are picked up by suction, conveyed into the inducer's venturi section and blown to a destination such as a PROCESS CONTROL film grinder or a waste container.

PROCESS CONTROL inducer manifolds are designed to insure that the air velocity at the pickup point is maintained so that trims do not wrap around the cutters.

The IN Series inducers feature an adjustable venturi to allow you to tune the inducer for peak performance with your installation.

IN Series inducers have a higher induced air to primary air ratio than conventional trim removal systems, providing excellent pickup and conveying performance.

IN Series inducers are designed to adapt easily to the installation requirements of your extrusion lines. The unit is shipped with its fan in a top-horizontal arrangement, but can be easily rotated in 90° increments to provide the required fan / venturi orientation. The fan may also be mounted remotely from the venturi using additional tubing.

Standard Features

- 3,7 – 15 kW AC, TEFC motors
- Standard electricals 400 / 3 / 50
- Electricals: Starter and controls are included in the grinder control panel when purchased as part of a complete asr® Automatic Scrap Recycling system. Controls are also available separately.
- Mild steel construction

Options

- Conveying hardware
- Trim pickup manifolds
- Special electricals
- Special paint

Trim Removal Inducers

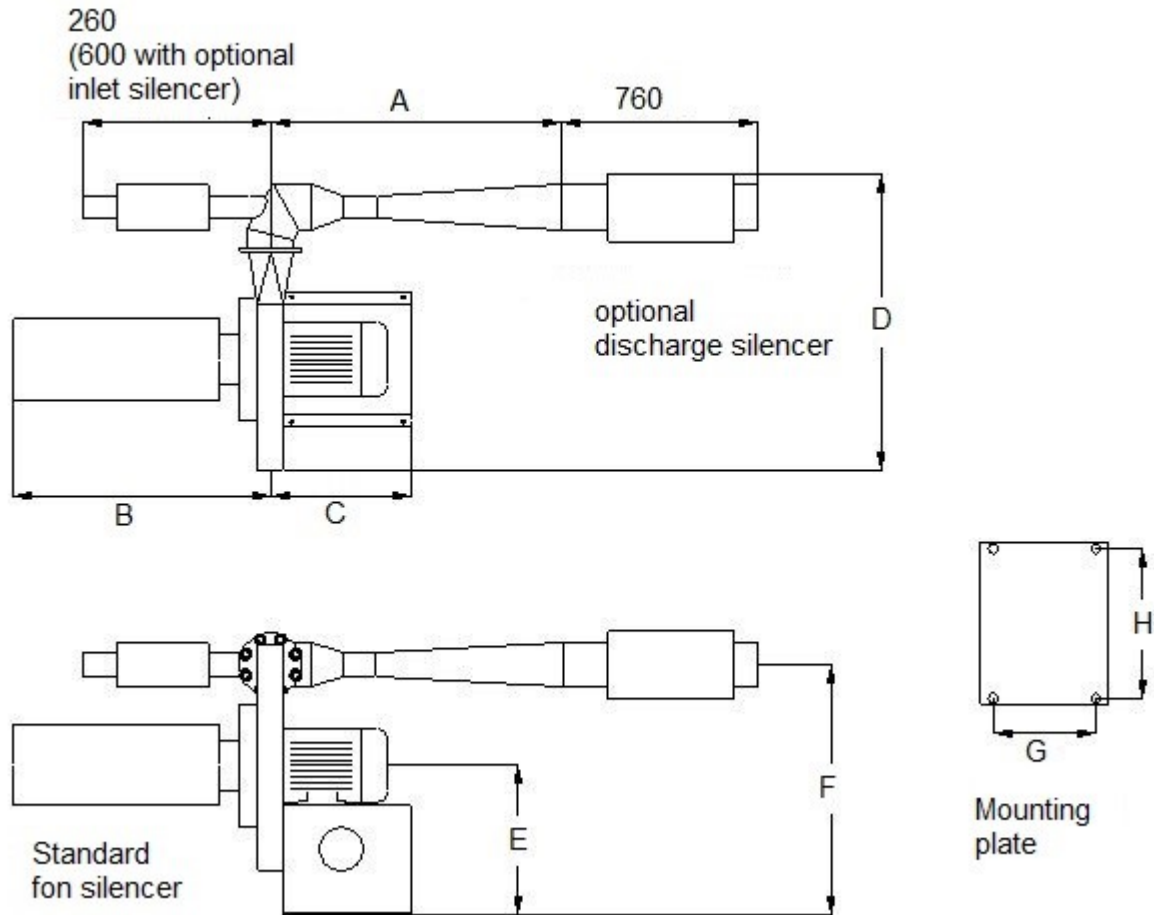

Specification

Model	Motor (kW)	Measurements (mm)								Inlet size (mm)	Outlet size (mm)
		A	B	C	D	E	F	G	H		
IN405	3,7	1115	635	400	885	400	660	178	356	102	168
IN415	11	1400	1215	620	1270	660	1115	495	552		203
IN420	15										



PROCESS CONTROL GmbH
 Industriestr. 15, 63633 Birstein, Deutschland
 Tel: (+49) 0 60 54 - 91 29 0 Fax: (+49) 0 60 54 - 91 29 99
 E-Mail: info@ProcessControl-GmbH.de
 Internet: www.ProcessControl-GmbH.de

PROCESS CONTROL Corporation
 6875 Mimms Drive, Atlanta, GA 30340 USA
 Tel: (+1) 770 449-8810 Fax: (+1) 770 449-5445
 Internet: www.Process-Control.com