

RMX-Series

Refeed Machine



The RMX Series: for use with asr® and Gravitrol® systems to recycle edge and / or bleed trims, tape, roll scrap and loose scrap, individually or simultaneously (pictured above is an RMX3)

The RMX Series Refeed Machine is part of a complete asr® Automatic Scrap Recycling System for recycling scrap generated on a film extrusion line. The RMX Series is specifically designed for use with Gravitrol® Gravimetric Extrusion Control Systems. The compact size also makes the RMX Series suitable for applications with headroom restrictions without sacrificing the performance that has made the asr® Refeed Machine popular for film applications.

The unique, patented double-compartment RMX Series Refeed Machine operates with a variable-speed auger / bridgebreaker assembly to compact and meter ground scrap from the inner hopper to the throat of the production extruder. The outer compartment contains virgin material which is gravity-fed to the throat. The virgin material completely surrounds the ground scrap as it enters the extruder. The extruder screw receives a consistent column of compacted ground scrap

surrounded by virgin material. This method provides consistent operation without extruder surging or starvation. With the standard extruder follower circuit, the refeed machine will increase the scrap rate in proportion to the extruder speed. This holds scrap percentage constant without additional operator attention.

Standard Specifications

Drive System:

AC motor flanged to hollow-shaft gearbox drives the single rotating member used to compact and refeed scrap. An VSC speed control includes adjustable torque limit, extruder screw following and signal isolation circuits. Start / Stop buttons, torque, speed and current will be displayed on a LCD screen. Mounted and wired in a NEMA-12 enclosure, 600 x 600 x 210 mm for remote mounting and wiring by others.

Electricals:

Power requirements: 400V, 50 Hz,

Materials of Construction:

Mild steel.

Paint:

RAL 7035 light grey (PC standard)

Options:

- other voltages
- additive feeders
- Trim Removal Inducers
- Film Scrap Grinders
- ground scrap high level switch interfaces with scrap grinder.

Refeed Machine

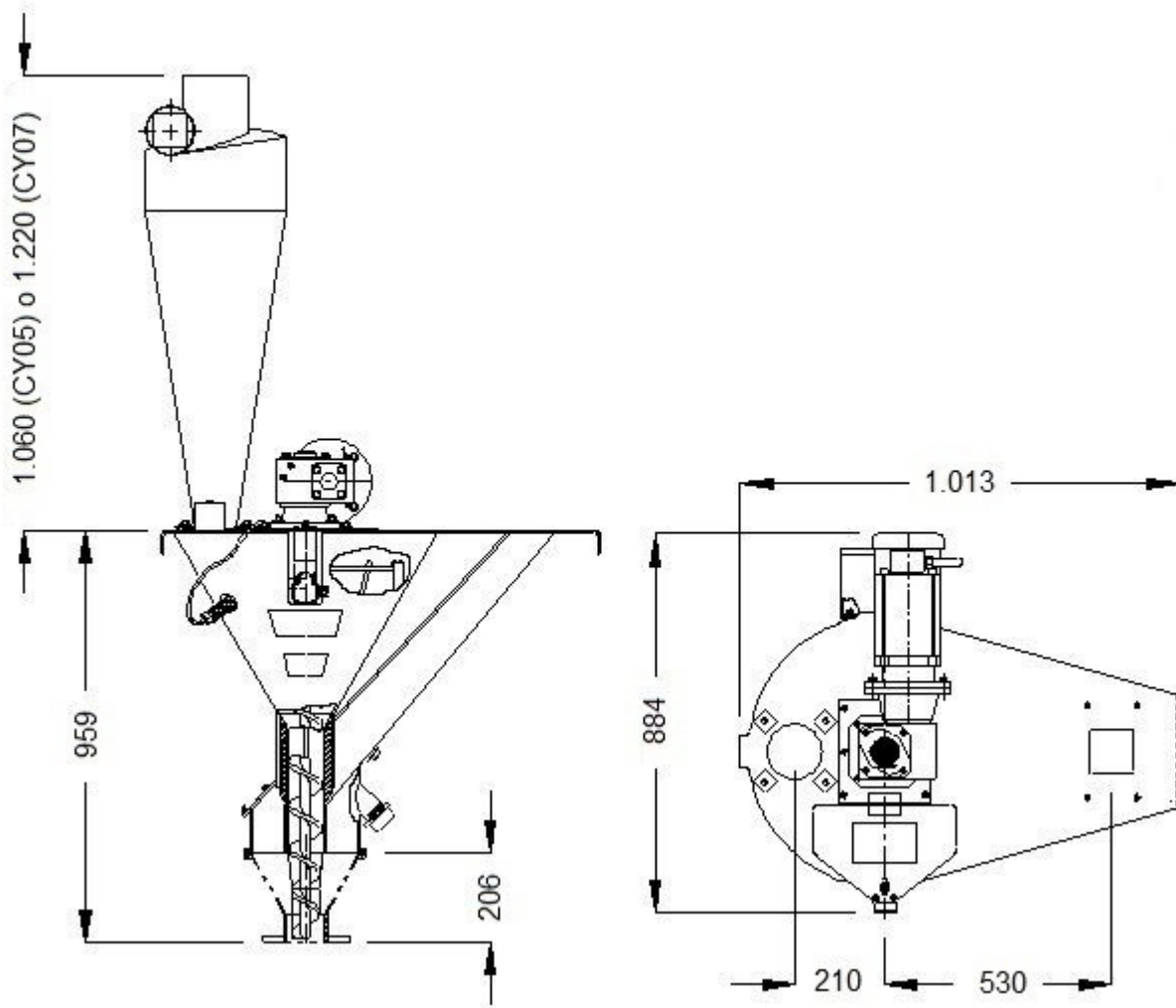

Specification

Model	Maximum Scrap Rate (dm ³ /h)	typical Extruder*	Auger Diameter	Usable Capacity		Power (kW)	Weight (kg)
				Scrap	Virgin		
RMX2	570	65-115	55	30	15	0,75	270
RMX3	1130	90-150	75				
RMX4	2550	115-200	100				
RMX5	3400	150-200	125				

* Match spool piece as closely as possible to extruder throat opening; spool piece opening must not exceed extruder throat opening.



PROCESS CONTROL GmbH
 Industriestr. 15, 63633 Birstein, Deutschland
 Tel: (+49) 0 60 54 – 91 29 0 Fax: (+49) 0 60 54 – 91 29 99
 E-Mail: info@ProcessControl-GmbH.de
 Internet: www.ProcessControl-GmbH.de

PROCESS CONTROL Corporation
 6875 Mimms Drive, Atlanta, GA 30340 USA
 Tel: (+1) 770 449-8810 Fax: (+1) 770 449-5445
 Internet: www.Process-Control.com